

A1. Wiring Ducts

A2. Cable Ties

A3. Din Rails

A4. Cable Markers

A5. Cable Clamps

A6. Wrapping Bands

A7. Nylon Cable Gland

A8. Metal Cable Gland

A9. Plastic Flexible Conduit

A10. Metal Flexible Conduit

A11. Terminal

A12. Copper Tube Terminals

A13. Heat Shrinkable Tubings

A14. Bus Bar Insulators

A15. Tool

A16. Cable Clip

A17. Insulating Nut

A18. Nylon Cable Carrier

CE RoHS EASCO® Bus Bar Insulators C Series (C型绝缘子)



Materials: BMC (Bough Moulding Compound) SMC (Sheet Moulding Compound).
Insert Material: Brass, Iron.

Working Temperature: -40°C ~ +140°C

Remark: Special color, insert, material is upon request by client with reasonable quantities.

材质: 不饱和聚酯树脂玻璃纤维增强模压塑料(BMC)(SMC).

嵌件: 黄铜、铁

工作温度: -40°C~+140°C

备注: 颜色、嵌件、材料性能可依客户需求定制, 但有起订量要求。

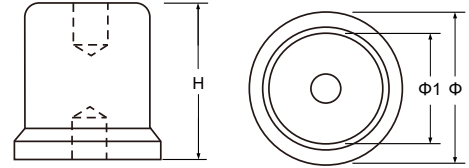

Article No.	Part No.	Tensile Strength (LBS)	Anti-Proof (KV)	Torgue Strength (FT LBS)	Screw	Screw Depth	H	Φ1	Φ	Material	Color
货号	型号	伸缩强度 (LBS)	耐压 (KV)	扭矩 (FT LBS)	螺纹	螺纹深度				材料	颜色
A0114.010.0001	C25	500	6	6	6	9	25	21	25	BMC	Red 红色
A0114.010.0002	C30	550	8	6,8	6,8	9,12	30	24	30	BMC	
A0114.010.0003	C40	650	12	12	8	12	40	30	40	BMC	
A0114.010.0004	C50	1000	15	12,20	8,10	12,15	50	40	50	BMC	
A0114.010.0005	C60	1200	20	20,40	10,12	15,18	60	45	60	BMC	
A0114.010.0006	C70	1500	22	20,40	10,12	15,18	70	45	60	BMC	

CE RoHS EASCO® Step Type Insulator (梯形绝缘子)

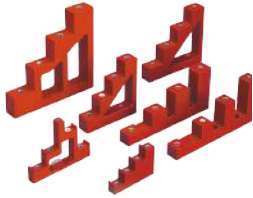

Materials: BMC (Bough Moulding Compound) SMC (Sheet Moulding Compound).

Insert Material: Brass, Iron.

Working Temperature: -40°C ~ +140°C

Remark: Special color, insert, material is upon request by client with reasonable quantities.

材质: 不饱和聚酯树脂玻璃纤维增强模压塑料(BMC)(SMC).

嵌件: 黄铜、铁

工作温度: -40°C~+140°C

备注: 颜色、嵌件、材料性能可依客户需求定制, 但有起订量要求。

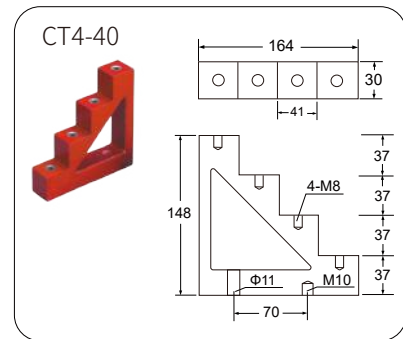
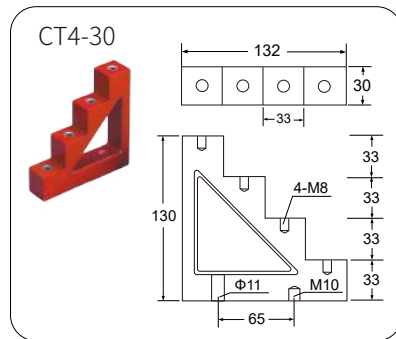
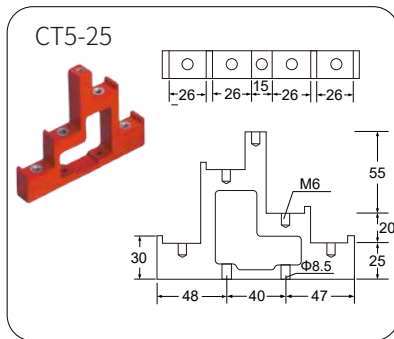
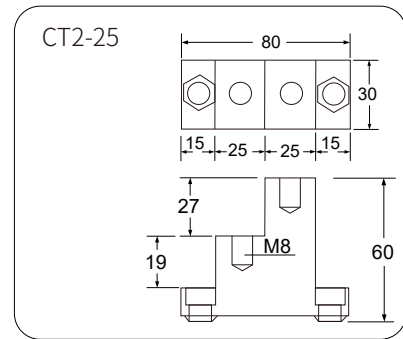
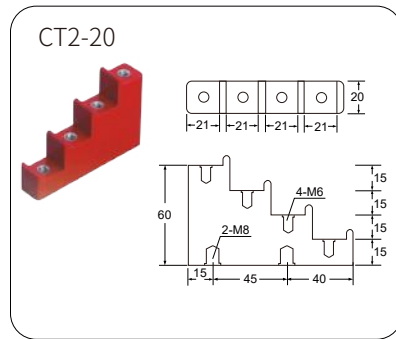
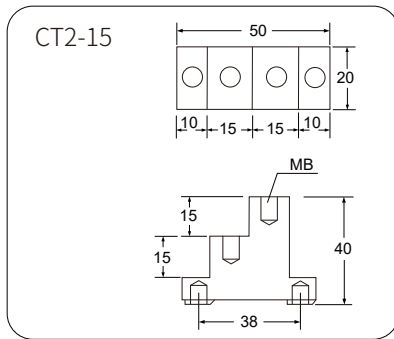

CE RoHS EASCO® Step Type Insulator (梯形绝缘子)

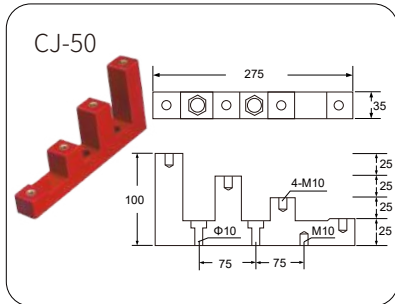
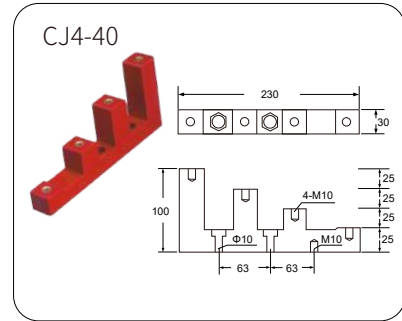
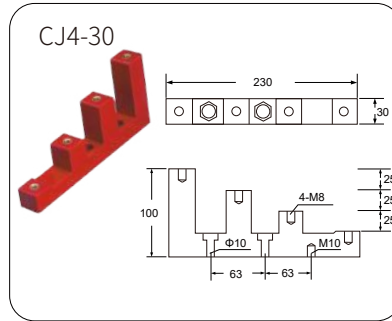
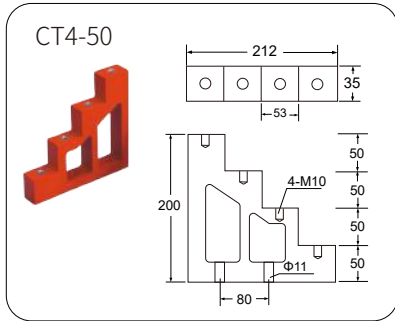

CE RoHS EASCO® High Voltage Insulator CL Series (CL系列铜排夹)

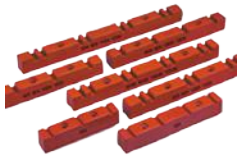

Materials: BMC (Bough Moulding Compound) SMC (Sheet Moulding Compound).

Working Temperature: -40°C ~ +140°C

Remark: Special color, insert, material is upon request by client with reasonable quantities.

材质: 不饱和聚酯树脂玻璃纤维增强模压塑料(BMC)(SMC)。

工作温度: -40°C~+140°C

备注: 颜色、嵌件、材料性能可依客户需求定制, 但有起订量要求。

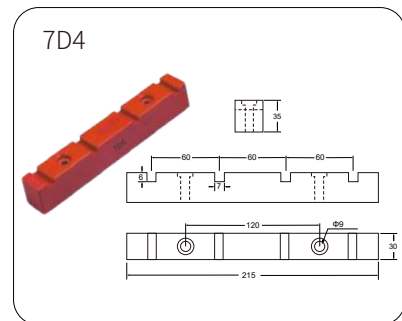
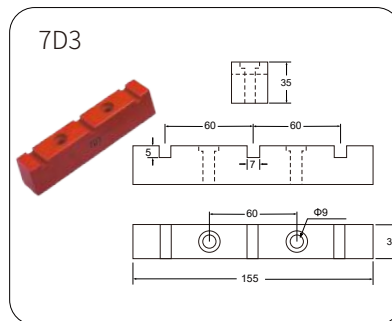
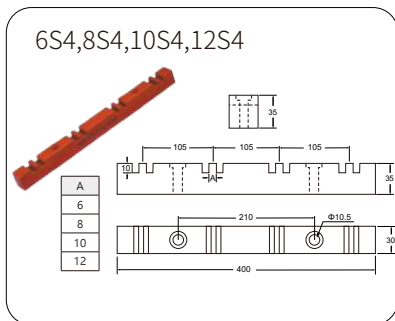
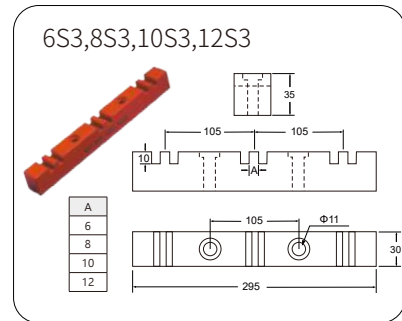
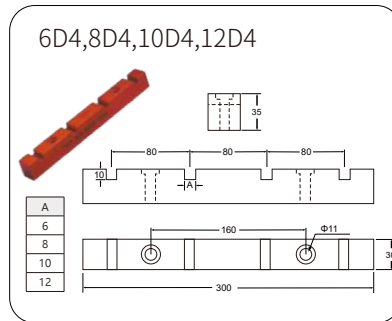
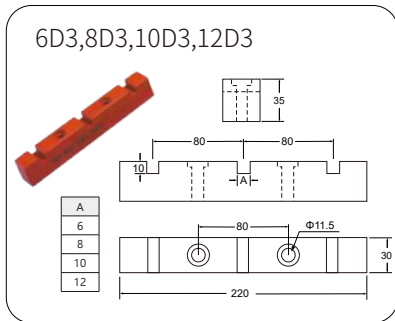

A1. Wiring Ducts

A2. Cable Ties

A3. Din Rails

A4. Cable Markers

A5. Cable Clamps

A6. Wrapping Bands

A7. Nylon Cable Gland

A8. Metal Cable Gland

A9. Plastic Flexible Conduit

A10. Metal Flexible Conduit

A11. Terminal

A12. Copper Tube Terminals

A13. Heat Shrinkable Tubings

A14. Bus Bar Insulators

A15. Tool

A16. Cable Clip

A17. Insulating Nut

A18. Nylon Cable Carrier